



gruppofesta s.r.l.
gruppofesta.it

NOLEGGIO E VENDITA
MACCHINE ED ATTREZZATURE



PALFINGER

P 280 AXE SMART
SEMPlicità, SICUREZZA
E PERFORMANCE
NELL'ALLESTIMENTO
PIÙ COMPATTO
DEL MERCATO

LIFETIME EXCELLENCE





DATI TECNICI P 280 AXE

Altezza massima di lavoro	27,80 m
Altezza massima piano piattaforma	25,80 m
Sbraccio laterale massimo	14,80 m
Angolo operativo del braccio di lavoro	-20° a + 80°
Angolo rotazione colonna	370°
Angolo di rotazione piattaforma	90° x 90°
Portata massima in piattaforma	230 kg
Dimensioni cestello	1,69 x 0,93 x 1,1 m
Altezza in condizioni di marcia	3,33 m
Larghezza in condizioni di marcia	2,25 m
Lunghezza in condizioni di marcia	6,67 m
Conducibile con patente C	

OPTIONAL

Cella di carico sul cestello
Cestello in vetroresina
Elettropompa 230 V
Faro di lavoro orientabile 60 W sul cestello
Isolamento 1000 V
Spondine in alluminio 200 mm
Verniciatura su richiesta del cliente parte aerea

DIAGRAMMI DI LAVORO

Piattaforma aerea dotata di 2 assetti stabilizzanti.

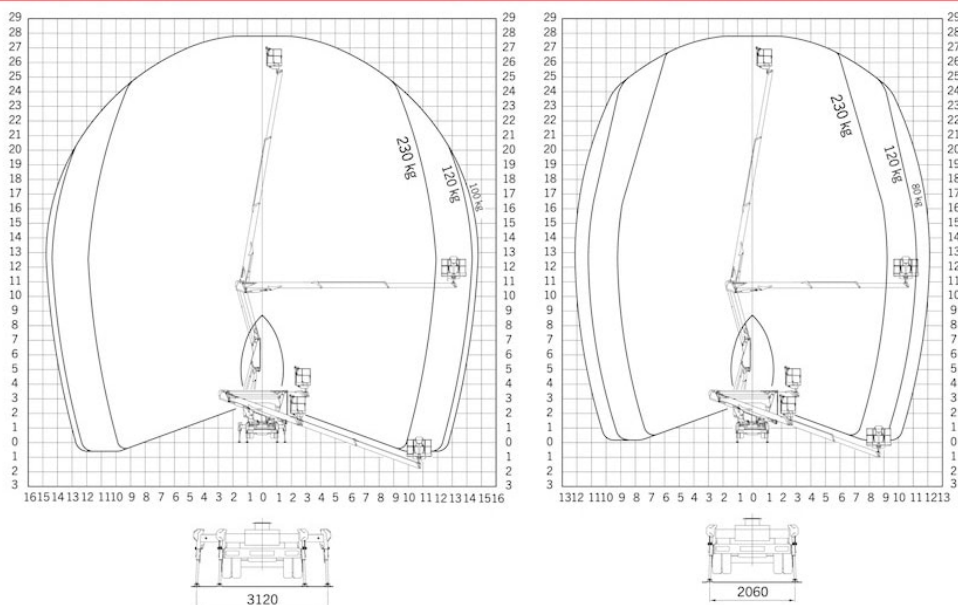

DIMENSIONI

